

Mechanical Properties of Mass-Produced Nanostructured Titanium

M. B. Ivanov^a, Yu. R. Kolobov^a, E. V. Golosov^a, I. N. Kuz'menko^a,
V. P. Veinov^b, D. A. Nechaenko^a, and E. S. Kungurtsev^a

^a State-Run Educational Institution of Higher Vocational Education, Belgorod State University, National Research University, Nanostructured Materials and Nanotechnology Research–Education and Innovation Center, ul. Pobedy 85, Belgorod, 308015 Russia

^b State Unitary Enterprise of the Republic of Tatarstan, All-Russian Scientific Research Institute of Medical Instruments, ul. Karima Tinchurina 31, Kazan, 420021 Russia
e-mail: Ivanov.Maxim@bsu.edu.ru

Abstract—The structure and mechanical properties of nanostructured titanium VT1-0 derived using an ingenious method which combines helical and longitudinal rolling are studied in comparison with the properties of commercial titanium alloys VT6 and VT16, as well as VT1-0 in a coarse-grained state. The mechanical properties of these materials are studied using quasi-static tensile and torsion tests (including finished products, i.e., implants for osteosynthesis), as well as fatigue tests. It is shown that the use of the developed method of severe plastic deformation is an efficient mode for the formation of a high-strength nanostructured state in titanium VT1-0, which exhibits sensitivity to stress concentrators under cyclic loading that is characteristic of titanium alloys and an extremely high reserve of torsional plasticity.

INTRODUCTION

The need for implants (dental, traumatologic, and orthopedic) available to the population of the Russian Federation currently exceeds the actual supply by 3–5 times. In addition, the market for these products is mainly occupied by foreign companies. The requirements for the materials (mostly metals and alloys) for the production of implants are constantly being tightened; they refer to increasing the biochemical and biomechanical compatibility with body tissues, improving the functional characteristics, and providing environmentally safe manufacturing procedures.

In Russia, commercially pure titanium VT1-0 and titanium alloys Ti–4Al–6V (VT 6), Ti–5Al–2Sn (VT 5-1), and Ti–2.5Al–5Mo–5V (VT 16) are most commonly used for the production of medical implants. The foreign counterparts to domestic titanium alloys are Grade-2 and Grade-4 alloys (so-called “commercially pure” titanium) and titanium alloy Ti–6Al–4V. All these alloys differ significantly in chemical composition and mechanical properties. Therefore, the problem of choosing a more perfect material for implants is of current concern. It should be noted that special requirements are imposed on the materials used in medical practice with respect to their strength and, in particular, fatigue properties, because in many cases they are intended for a long-term use and premature failure is unacceptable. In this regard, the alloy Ti–6Al–4V (domestic counterpart VT6) is the best of these materials. The strength of this alloy is

enhanced due to the introduction of aluminum and vanadium into its composition. However, these doping elements have a deleterious effect on biological objects [1]. In terms of better biocompatibility, alloys from the group of “pure” undoped titanium (VT1-0, Grade-4) are more promising.

One alternative for the preservation of high biochemical compatibility with the necessity of improving the complex of mechanical properties of titanium alloys is the previously developed approach based on the formation of submicrocrystalline or nanostructured (NS) states in commercially pure titanium [2–5] that does not contain elements that are harmful for living bodies. In accordance with the adopted terminology, metals and alloys with grain sizes in a range of 10^2 – 10^3 nm as classified as submicrocrystalline materials and those with grain sizes less than 100 nm constitute NS materials. However, in many cases, the amount of nanoscale grains (with a diameter less than 100 nm) in the structure of metals and alloys with an average grain size of a few hundred nanometers can be a few or a few tens percent. In addition, it is the presence of nanoscale grains that governs the unique mechanical, physical, and other properties. In connection with this, in our opinion, the materials that exhibit unique properties owing to a significant (a few tens of a percent) amount of nanoscale grains in the material structure can be regarded as NS metals and alloys.

MECHANICAL PROPERTIES OF MASS-PRODUCED NANOSTRUCTURED TITANIUM

Table 1. Chemical composition of studied titanium alloys VT1-0, VT6, and VT16*

Alloy	Content of elements, wt %, Ti-base									
	Al	Mo	V	Zr	Fe	Si	O ₂	C	N ₂	H ₂
VT1-0	0.01	—	—	—	0.12	0.002	0.143	0.004	0.003	0.0008
VT6	6.46	—	3.84	0.02	0.083	0.010	0.166	0.005	0.003	0.003
VT16	3.21	5.40	4.42	0.11	0.11	0.072	0.140	0.011	0.016	0.003

* According to the certificate of conformity of JSC VSMPO-AVISMA.

However, most of the known methods for forming the above states using severe plastic deformation [2, 6–12] are inefficient and significantly increase the cost of the material. It is shown in [13] that one of the most promising methods for forming the above states in undoped titanium (alloy VT1-0) with high strength characteristics in terms of high efficiency and low cost is the method that combines helical and longitudinal rolling [14]. At present, this method is used in the mass production of rods and profiles of nanostructured VT1-0 and Grade 4 at the LLC “Metall-deform” small innovative enterprise of Belgorod State University. This material is used to produce a set of implants for the osteosynthesis of tubular bones (Technical Specifications TU 9438-031-47080839-2009 “Implants for the Traumatology of Nanostructured Titanium Alloys”; the producer is the State Unitary Enterprise of the Republic of Tatarstan, All-Russian Scientific Research Institute of Medical Instruments, Kazan; Roszdravnadzor (Federal Service for the Supervision of Public Health and Social Development) registration certificate no. FSR 2009/05990, certificate no. ROSS RU.IM06.V01126), which is supplied to clinical units of the Russian Federation.

In this work we describe the results of a study of the structure and mechanical properties (tensile, fatigue, and torsion tests, particularly finished products, i.e., screws for osteosynthesis) of mass-produced undoped titanium VT1-0 in an NS state in comparison with alloys VT6 and VT16 and coarse-grained VT1-0.

MATERIALS AND METHODS

The research material was titanium VT1-0 (supplied by JSC VSMPO-AVISMA, Verkhnyaya Salda). The amount of impurities in VT1-0 and the chemical composition of alloys VT6 and VT16 are listed in Table 1.

Using the serial modes of the thermomechanical processing of alloy VT1-0 and longitudinal and helical rolling [13, 14], we obtained NS rods with a diameter of 8 mm according to Technical Specifications TU 1825-001-02079230-2009. After the formation of the nanostructure, the entire material was subjected to finishing annealing at a temperature of 350°C for 3 h to relieve internal stresses.

The structure of titanium alloys was studied in a section longitudinal to the direction of rolling using a

Quanta 600 FEG scanning electron microscope with field emission. The average grain size in each sample was determined via plotting grain size distribution diagrams as the “center of gravity” of this histogram. The samples were prepared by mechanical grinding and polishing using LaboPol-5 (Struers) setups and the subsequent electropolishing of the sample surface using a LectroPol-5 (Struers) setup in a solution of 60 ml NClO_4 + 600 ml CH_3OH + 360 ml $\text{CH}_3(\text{CH}_2)_2\text{CH}_2\text{OCH}_2\text{CH}_2\text{OH}$ at a temperature of +5°C and a voltage of $U \approx 23$ V

Detailed studies of the microstructure of NS VT1-0 were carried out by electron back-scatter diffraction (EBSD) using an EDAX accessory to a Quanta 600 FEG scanning electron microscope and the TexSem Lab (TSL) software at an accelerating voltage of 20 kV, a current of 26 nA, and a scanning pitch of 30 nm.

The mechanical properties of NS titanium alloy VT1-0 were studied in comparison with the properties of the above-mentioned titanium alloys VT6 and VT16, which are widely used in the production of medical bone implants.

The mechanical tensile tests were performed at room temperature using an Instron 5882 testing machine with a strain rate of 1.5 mm/min. We used planar samples (with dimensions of the working part of $4 \times 5 \times 25$ mm³) and round samples (with a diameter of 4 mm and a length of the working part of 25 mm). The degree of strain of the samples was measured using an Instron strain gage. The planar samples were cut in the form of blades from the rod by electrospark cutting; the round samples were prepared using a lathe tool. The working surfaces of the samples were subjected to mechanical grinding. According to the results of tensile tests of mechanical properties, we determined strength characteristics and plastic properties: yield strength ($\sigma_{0.2}$), ultimate strength (σ_B), uniform elongation (δ_0), and elongation to failure (δ).

For the torsion bending fatigue tests, we used an Instron RRM-A2 high-speed testing machine. The rotation frequency was 50 Hz. The studies were carried out for smooth samples (the form is shown in Fig. 1a) and samples with a V-notch, which simulated a threaded groove with a radius of $R = 0.3$ mm at the bottom (Fig. 1b). To compare the fatigue limit of the titanium alloys under study, we plotted fatigue curves (Wöhler curves) in semilogarithmic coordinates [15, 16].

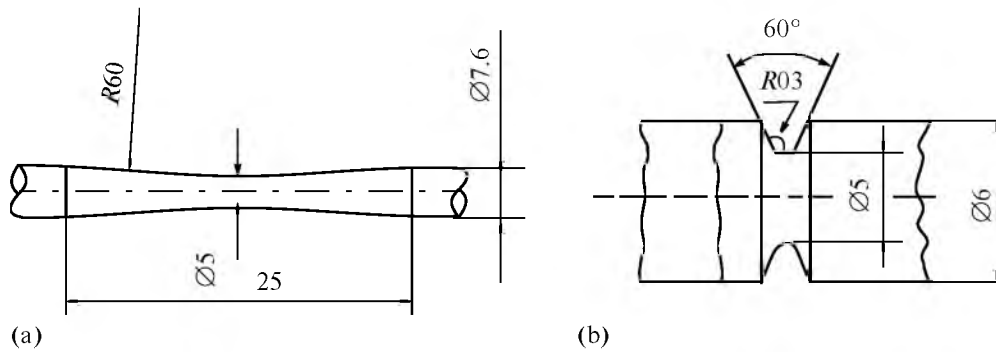

Fig. 1. Sizes of the working part of the sample for torsion bending-fatigue tests: (a) smooth sample and (b) sample with a V-notch.

The fatigue strength at a number of cycles of 10^7 was determined according to the curve, the equation of which was fitted by least-squares method by experimental points.

The torsion strain curves (torque–torsion angle) were obtained using a setup that was prepared at the Nanostructured Materials and Nanotechnology Research–Education and Innovation Center according to the requirements of State Standard GOST 3565-80. The torsion angle and torque of the samples were measured using this setup. The size of the working part of the sample was $\text{Ø}3.4 \times 8$ mm. The calculation of shear stress by the recorded value of torque was performed in accordance with GOST 3565-80 by the formula

$$\tau = \frac{T}{W_p}, \quad (1)$$

where T is the torque and W_p is the resistive torque: $W_p = \pi D^3/16$ (D is the diameter of the working part of the sample).

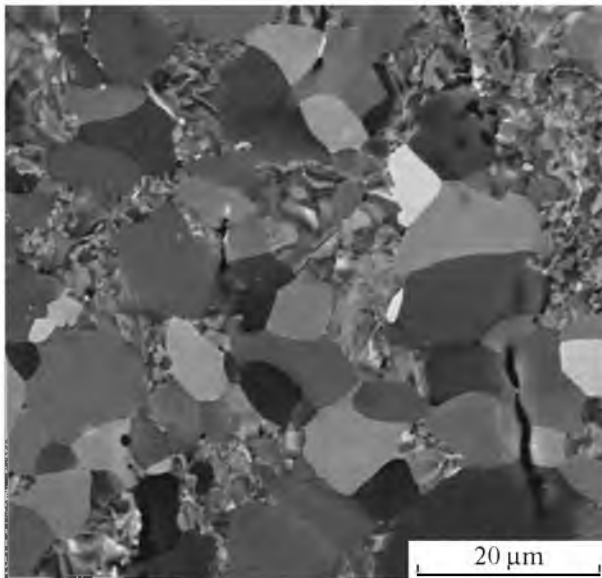

Fig. 2. Microstructure of titanium VT1-0 in the original state. Scanning electron microscopy.

The mechanical torsion properties of cortical screws were determined according to GOST 50581-93 (ISO 6475-89). The dependence that torque has on the torsion angle to failure of screw heads was studied. The studies were carried out for screws with an outer diameter of 4.5 mm; the screws were fixed so that five screw threads subject to torsional strain remained open.

EXPERIMENTAL RESULTS

In the original state (as-received condition), titanium VT1-0 has a partially recrystallized structure (Fig. 2) with an average size of elements of the grain-subgrain mixture of $d = 4.7 \mu\text{m}$; the size of recrystallized grains in this material is $\sim 10 \mu\text{m}$.

The microstructure of alloy VT6 comprises equiaxial grains of the primary α -phase with sizes of about $20 \mu\text{m}$ and the β -transformed structure with plates of the α -phase with a thickness of about $4 \mu\text{m}$. They alternate with interlayers of the β -phase that are about $2 \mu\text{m}$ in size (Fig. 3a). The microstructure of alloy VT16 comprises a mixture of α and β phases (Fig. 3b). A large part of the material bulk has a platelike structure. The length of the plates is 15 to $50 \mu\text{m}$, and the thickness is 1 to $3 \mu\text{m}$.

Due to the effect of severe plastic deformation by the method that combines helical and longitudinal rolling, a cross-sectionally uniform NS state was formed in the titanium VT1-0 under study. Inhomogeneities in the form of large grains or discontinuities (pores and cracks) were not observed in the structure of the material. This was also confirmed by the measurements of density by hydrostatic weighing and a modified method of small-angle X-ray scattering [17].

The results of the EBSD analysis show that the microstructure fragments mostly have a shape elongated along the axis of rolling (Fig. 4). The amount of high-angle boundaries is on the order of 76% (Fig. 5). The average grain size is $0.29 \mu\text{m}$ (Fig. 6) at a nonequiaxiality coefficient of 0.36.

The results of mechanical tensile tests of the alloys under study are presented in Table 2. The formation of

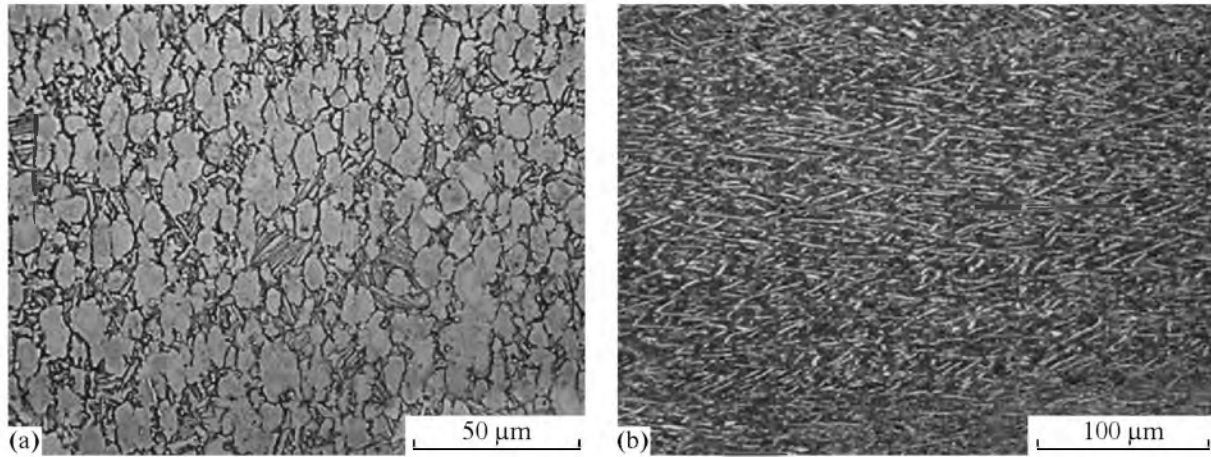

Fig. 3. Microstructure of (a) VT6 and (b) VT16 alloys. Optical metallography

a nanostructure in VT1-0 using the proposed method that combines the helical and longitudinal rolling leads to a significant (almost twofold) increase in the yield strength ($\sigma_{0.2}$) and ultimate strength (σ_B) in comparison with the original state.

Note that the strength characteristics of NS titanium VT1-0 are lower by approximately 5–10% than those of doped alloys VT6 and VT16; at the same time, the plasticity (elongation to failure) is significantly higher in NS VT1-0.

As the size of structural elements (grains and sub-grains) decreases, metallic materials exhibit an increase in strength characteristics both under static

loading and cyclic fatigue testing. For cyclic loading, the dependence that fatigue strength σ_{-1} has on grain size d is expressed by a well-known formula similar to the Hall–Petch relationship and the respective relation $\sigma_{-1} \approx kd^{-1/2}$. However, this relation is not always fulfilled for NS materials [18]. It should be noted that fatigue testing is one of the main types of tests for medical implants and the materials used for their manufacture.

The presence of stress concentrators in metallic materials due to defects such as scratches and notches, as well as design features (holes and threads), leads to a decrease in the fatigue limit. It should be noted that a fatigue crack as such is a notch that causes a high stress concentration. The local stress in the material increases in the region of a concentrator. The true stress at the concentrator tip σ_{max} is considerably larger than the nominal σ_n . The ratio $\sigma_{max}/\sigma_n = \alpha_\sigma$ is called

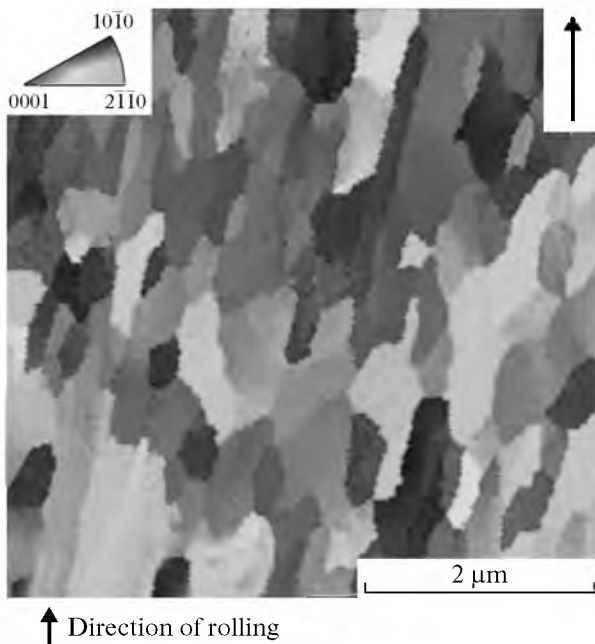

Fig. 4. EBSD map in the color scale of the crystallographic triangle of the hcp lattice of titanium. NS state of VT1-0.

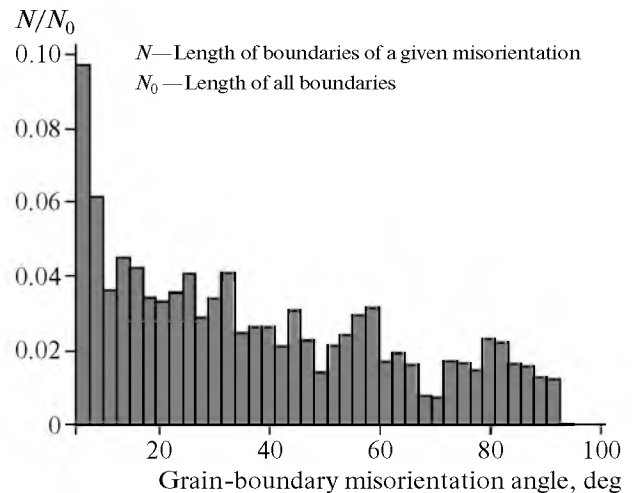

Fig. 5. Grain-boundary misorientation angle distribution in NS titanium VT1-0 according to EBSD data.

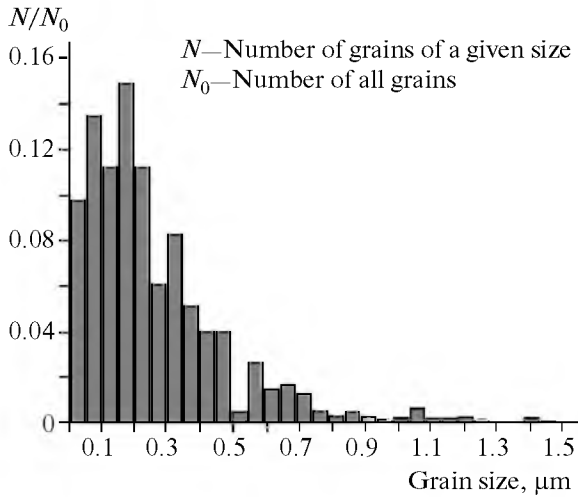

Fig. 6. Grain size distribution in NS titanium VT1-0 according to EBSD data.

the theoretical stress concentration factor in their elastic distribution. It is known from the literature that the theoretical stress concentration factor for the type of samples studied in this work (Fig. 1b) is about 3.3. The decrease in fatigue limit in the presence of a stress concentrator is estimated through effective stress concentration factors:

$$K_{\sigma} = \frac{\sigma_{-1}}{\sigma_{-1K}}, \quad (2)$$

where σ_{-1} is the fatigue strength without a concentrator and σ_{-1K} is the fatigue strength with a stress concentrator. This value (2) characterizes the notch sensitivity of the material.

Table 3 shows the experimentally derived values of the fatigue strength of the studied titanium alloys (Fig. 7) and the effective stress concentration factor calculated from relation (2) for the V-notch used in this work.

Figure 7 shows that the formation of a nanostructure in titanium alloy VT1-0 leads to an increase in the fatigue strength by about 50% relative to the original state (Fig. 7a, Table 3) for the values derived in tests both with a stress concentrator and without it. However, the most interesting results obtained in fatigue tests are data on notch sensitivity (Table 3). It is

Table 2. Mechanical properties (yield strength $\sigma_{0.2}$ and ultimate strength σ_B) under tensile tests of VT1-0 in the original and NS states and alloys VT6 and VT16 in the original state

Material	$\sigma_{0.2} \pm 10$, MPa	$\sigma_B \pm 10$, MPa	δ_p , %	δ , %
orig. VT1-0	376	490	13	29
NS VT1-0	786	915	2.1	6.8
VT6	912	961	6.5	11
VT16	939	1002	5	9

assumed that the development of a crack in an NS material in the presence of a stress concentrator must occur more intensively than for a coarse-grained state. These results show that, for NS titanium alloy VT1-0, the notch sensitivity has no significant differences in the values of K_{σ} (Table 3) when compared to the coarse-grained state of VT1-0 and alloy VT6.

Tests of the finished products are of the greatest interest for practical applications. These materials for medical purposes include, first and foremost, screws for traumatology. Note that the materials for screws for medical purposes must exhibit not only a significant mechanical tension–compression and fatigue strength, but also a considerable torsional plastic strain at a high shear stress. Figure 8 shows the dependence of torque on the torsion angle of screw heads for osteosynthesis (cortical screws) with a diameter of 4.5 mm of NS titanium VT1-0 and coarse-grained alloy VT16 in the as-received condition. It is evident from Fig. 8 that the screws of NS titanium VT1-0 are not inferior in strength to those of alloy VT16; in addition, they exhibit an extremely high plasticity (maximum torsion angle to failure).

To compare the test data for screws (Fig. 8) with the test data for cylindrical samples (in accordance with GOST 3565-80), see Table 4, which presents the results of torsion tests of titanium alloys VT6 and VT16 in a coarse-grained state and titanium VT1-0 in an NS state. In this table, φ_{\max} is the torsion angle at failure, $\tau_{0.3}$ is the yield strength in torsion, and τ_{ult} is the ultimate strength in torsion. According to the test results, NS VT1-0 is not only not inferior in strength to alloys VT6 and VT16, but it also exhibits extremely high plasticity (the maximum torsion angle to failure is 410°), which is almost twice as high as that of alloy VT6 and three times as high as that of alloy VT16.

RESULTS AND DISCUSSION

The reserve of plasticity is an important factor of reliability, because, under conditions of a real medical prosthesis, the destruction of screws made of a conventional titanium alloy sometimes occurs as early as during the installation of the construction. The most common type of destruction is “torque failure” of a screw head during its threading into a predrilled bone. As a result, a surgeon must drill out the remainder (threaded portion) of the screw from the bone and change the configuration of the construction to be installed using other means for fixing. This procedure leads not only to an unexpected increase in the time of surgery, but also to an increase in the risk of implants improperly functioning, particularly when employing compression-type plates.

According to GOST R 50581-93, cortical screws of stainless steel with an outer diameter of 4.5 mm must withstand a minimum torque without failure of 4.4 N m at a minimum torsion angle of the screw head (φ_{\min})

MECHANICAL PROPERTIES OF MASS-PRODUCED NANOSTRUCTURED TITANIUM

Table 3. Fatigue strength under tests with a stress concentrator (notch) and without it; effective stress concentration sensitivity (K_σ) for titanium VT1-0 and alloy VT6

Material	Sample geometry	σ_{-1} , MPa at $N = 1 \times 10^7$	$K_\sigma = \frac{\sigma_{-1}}{\sigma_{-1K}}$	$\frac{\sigma_{-1}}{\sigma_B}$
orig. VT1-0	smooth	350	1.8	0.7
	notched	190		0.4
NS VT1-0 ($d_{av} = 0.29 \mu\text{m}$)	smooth	490	2.0	0.5
	notched	240		0.3
VT6	smooth	600	2.0	0.6
	notched	300		0.3

of no less than 180° . The above parameters for screws of titanium alloys are absent in the literature. Being guided by GOST R 50581-93, we can state that the mass-produced screws of titanium alloy VT16 (alloy VT6 shows similar results) withstand the minimum torque, while the torsion angle at failure averages 100° . At the same time, screws made out of NS titanium VT1-0 have a maximum torsion angle to failure that significantly exceeds the value of $\varphi_{\min} = 180^\circ$ that is specified in Russian and international standards (Fig. 8).

Our data on the torsion of cylindrical samples (Table 4) and screws (Fig. 8) change the notion of NS metals as materials with low plasticity. A decrease in plasticity is usually imputed to NS materials as a disadvantage of their practical use and processibility. However, to date, it is reliably found that low plasticity, including that of NS titanium, is due to the formation of localized deformation bands at early stages of yielding (1–2%). A significant role in the localization and, as a result, plasticity of the NS material is played by the geometry of the sample [19]. In most cases, the narrowing in the neck remains high. An analysis of these results (Table 2) suggests that the solid-solution

strengthening (due to doping elements in alloys VT6 and VT16) is largely equivalent in most parameters to the substructure and grain-boundary strengthening of NS titanium VT1-0. However, for some types of tests (patterns of deformation), for example, torsion tests, the reserve of plasticity of a pure metal (in this particular case, titanium) with an NS structure is several times higher than that of an alloy on its basis with an equivalent strength. This can probably be attributed to another unique property of materials with ultrafine grains. Nevertheless, in the opinion of the authors, the observed torsional behavior of NS titanium can be reasonably explained as follows.

As the grain size decreases and the volume fraction of the material related to the grain boundaries accordingly increases, their role in the implementation of deformation mechanisms, such as grain-boundary sliding (GBS) and diffusion creep, increases (recent reviews on this problem include [5, 20, 21]). As this takes place, the role of intragranular dislocation slip decreases, because the occurrence of dislocations in nanograins is energetically unfavorable. Thus, in NS materials where the number of nanoscale grains is a

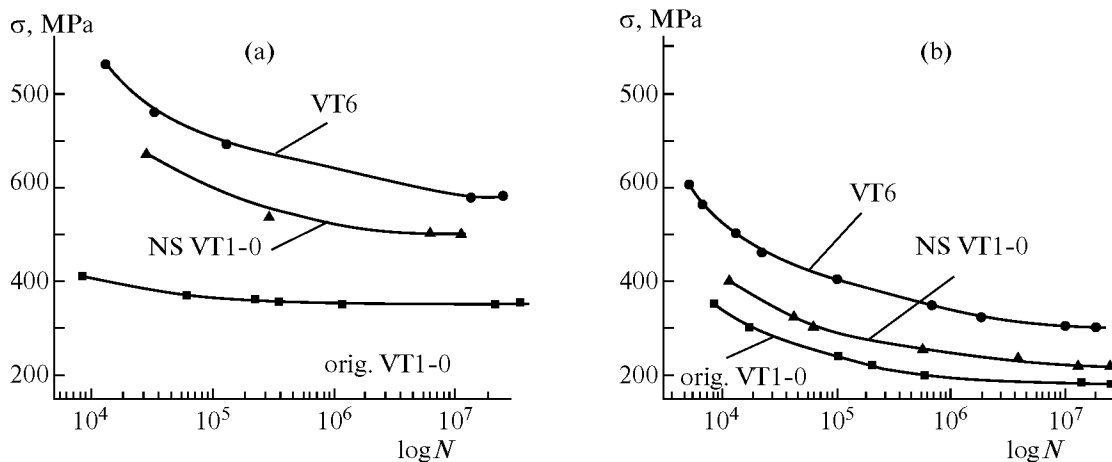
Fig. 7. Dependences of stress amplitude on the number of cycles until the failure of NS titanium VT1-0 in comparison with alloy VT6: (a) smooth and (b) notched samples.

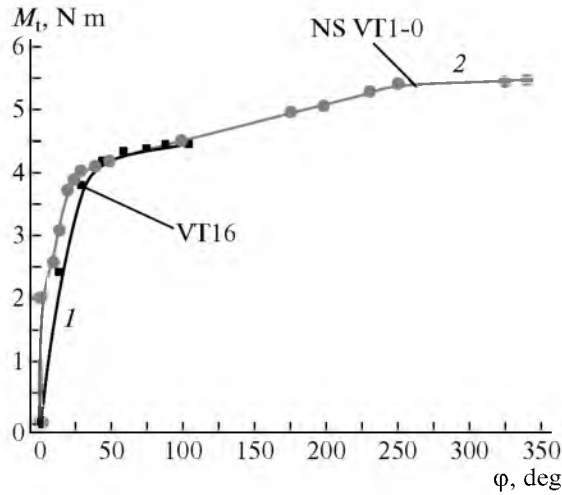

Fig. 8. Dependence of torque on torsion angle under torsion tests of cortical screws with a diameter of 4.5 mm: (1) alloy VT16 in a coarse-grained state and (2) titanium VT1-0 in an NS state.

few tens of a percent, the GBS, including the cooperative GBS [22], can effectively compete with the motion of lattice dislocations even at room temperature, because the nonequilibrium state of grain boundaries leads to a significant decrease in the resistance to GBS due to a significant increase in diffusion coefficients [23–25]. Under torsion tests (pattern of simple shear stress state), a homogeneous nanostructure makes it possible to implement cooperative GBS with a high density of localized shear bands parallel to one another. This makes it possible to obtain high degrees of deformation without significant strengthening and the destruction of the sample. It is most probably this effect that leads to a high torsional plasticity of both smooth samples and threaded constructions (cortical screws for osteosynthesis) made of NS titanium VT1-0.

The increase in the mechanical properties (yield strength and ultimate strength) and the resistance to fatigue failure of metallic materials subjected to severe plastic deformation was observed and studied in detail in numerous works of Russian and foreign authors (see, e.g., reviews [2, 8, 18]). However, fairly convincing examples of the manifestation of unique mechanical properties, one of which is the sensitivity to the stress concentrator under the cyclic loading of NS tita-

nium in comparison with its fine-grained state, were found and studied only in recent years. The first preliminary results are summarized in [6]. The results of more detailed studies, which represent comparative data for NS titanium and fine-grained titanium and its alloys, are described in this work.

The absence of a significant increase in the value of sensitivity to stress concentrator with increasing fatigue strength makes it possible to improve the structural strength of metallic materials. This opens up the possibility to use alloy VT1-0 with nanoscale grains for the formation of constructions that were previously prepared only from high-strength doped titanium alloys (of the VT6 and VT16 types). The appearance of the above positive characteristic is directly related to the initial idea of using severe plastic deformation to form a nanoscale grain-subgrain structure in the metal (with the amount of high-angle grain boundaries of more than 70–80%). It is impossible to obtain this structure by recrystallization after conventional deformation. We can assume that it is the grain structure of an NS material that is responsible for the value of the sensitivity to the stress concentrator close to that of fine-grained titanium. In this regard, according to the terminology of the authors described in the Introduction, NS materials are those in which the amount of nanoscale grains is a few tens of a percent. One of the methods to obtain this nanostructure with high-angle grain boundaries is helical rolling and its combination with monotonic deformation [13], which was used in this work to prepare NS titanium VT1-0 (Fig. 4).

It should be noted that the coarse-grained titanium VT1-0 (the original material used in this work) in the as-received condition had a partially recrystallized structure (Fig. 2). Owing to the medical use of titanium and clinical trials of products made of it [5], this material in the as-received condition had a minimum content of aluminum (the actual content was 0.01 wt % with requirements of <0.7 wt % according to OST1 90013-81; Table 1). To meet the requirements of OST1 90173-75 in terms of strength (400–550 MPa), the mode of rolling at the producer enterprise (JSC VSMPO-AVISMA) was modified; in particular, an incomplete recrystallization annealing was carried out. Thus, the derived data on the sensitivity of coarse-grained titanium VT1-0 to stress concentrator are not entirely consistent with the current data for a completely recrystallized material; they characterize its partially recrystallized state. This confirms the assumption of the key role of an ensemble of grain boundaries in the formation of the mechanical properties of NS materials even more, because, in many works, a grain-subgrain mixture with dominant small-angle boundaries is taken for a nanostructure.

Nevertheless, it should be noted that the physical nature of the preservation of low sensitivity to stress concentrator for NS titanium is not completely understood. It is known that a decrease in grain size in a globular structure increases the fatigue crack growth

Table 4. Mechanical torsion properties of NS titanium VT1-0 and mass-produced VT6 and VT16 alloys

Material	d , mm	l , mm	φ_{\max} , deg.	$\tau_{0.3} \pm 10$, MPa	$\tau_{\text{ult}} \pm 10$, MPa
NS VT1-0	3.40	8.0	410	465	773
VT6	3.40	8.0	260	580	770
VT16	3.40	8.0	142	671	800

rate [26], which was also confirmed for NS titanium [27]. It is worthy to note in this case that the kinetic diagrams of fatigue failure of NS titanium in [27] and fine-grained alloy VT6 with equiaxial grains of about 2 μm [26] are close at the same stress ratio. Despite the notion of NS titanium as a high-strength state of this material, it is found that it has a greater tendency to strengthening under cyclic loading [8] (this is not typical for metallic materials under fatigue [15]) than a coarse-grained material. The close values of fatigue crack growth rates in alloy VT6 and undoped NS titanium, as well as the strengthening under cyclic loading, implicitly show the absence of a “catastrophic” increase in the sensitivity to a stress concentrator in an NS state. This was experimentally confirmed in this work.

CONCLUSIONS

The structure and mechanical properties of mass-produced NS titanium VT1-0 derived using a technique that combines helical and longitudinal rolling are studied in comparison with the properties of commercial titanium alloys VT6 and VT16, as well as alloy VT1-0 in a coarse-grained state.

It is found that the NS state of undoped titanium VT1-0 with mostly a grain structure (the amount of high-angle grain boundaries is 75% and more) exhibits a significantly higher plasticity under torsion tests of both smooth cylindrical samples and threaded constructions (screws for osteosynthesis) in comparison with that of doped titanium alloys with an equivalent strength.

The formation of an NS state in titanium does not lead to a catastrophic increase in sensitivity to a stress concentrator under cyclic loading. The value of sensitivity to a stress concentrator obtained in the torsion bending fatigue tests is characteristic of coarse-grained titanium alloys and titanium VT1-0 in a partially recrystallized state.

The analysis of the results shows that the solid-solution strengthening of titanium due to doping elements (implemented in alloys VT6, VT16, etc.) is equivalent to the grain-boundary strengthening, which is implemented through the formation of a nanostructure in undoped titanium with respect to the change in most parameters of mechanical properties at room temperature (strength and plasticity, fatigue strength, and sensitivity to stress concentrator under cyclic loading). It is assumed that the decrease in grain size to a nanoscale level leads to the appearance of high-temperature deformation mechanisms even at room temperature, which helps improve the plasticity characteristics of NS metals.

This work was supported by the Federal Target Program “Research and Scientific–Pedagogical Personnel of an Innovative Russia” for 2009–2013, State contract no. 14.740.11.0705 dated October 12, 2010; State contract no. 16.740.11.0025 dated September 1,

2010; and project no. 2.1.2/1061 of the Analytical Departmental Target Program “Development of Scientific Potential of Higher Education” with the use of analytical equipment from the “Diagnostics of the Structure and Properties of Nanomaterials” Center for the Collective Use of Scientific Equipment at Belgorod State University.

REFERENCES

1. O. Yoshimitsu, R. Sethumadhvan, I. Yoshimasa, and T. Tetsuya, “Corrosion Resistance, Mechanical Properties, Corrosion Fatigue Strength, and Cytocompatibility of New Ti Alloys without Al and V,” *Biomaterials*, No. 19, 1197–1215 (1998).
2. E. F. Dudarev, O. A. Kashin, Yu. R. Kolobov, G. P. Pochivalova, K. V. Ivanov, and R. Z. Valiev, “Microplastic Deformation of Polycrystalline and Submicrocrystalline Titanium during Static and Cyclic Loading,” *Izv. Vyssh. Uchebn. Zaved., Fiz.*, No. 12, 20–25 (1998) [*Russ. Phys. J.* **41** (12), 1188–1192 (1998)].
3. Yu. R. Kolobov, O. A. Kashin, E. E. Sagymbaev, E. F. Dudarev, L. S. Bushnev, G. P. Grabovetskaya, G. P. Pochivalova, N. V. Girsova and V. V. Stolarov, “Structure and Mechanical and Electrochemical Properties of Ultrafine-Grained Titanium,” *Izv. Vyssh. Uchebn. Zaved., Fiz.*, No. 1, 77–85 (2000) [*Russ. Phys. J.* **43** (1), 71–78 (2000)].
4. Yu. R. Kolobov, R. Z. Valiev, G. P. Grabovetskaya, A. P. Zhilyaev, E. F. Dudarev, K. V. Ivanov, M. B. Ivanov, O. A. Kashin, and E. V. Naidenkin, *Grain-Boundary Diffusion and Properties of Nanostructured Materials* (Nauka, Novosibirsk, 2001; Cambridge International Science Publishing, Cambridge, 2007).
5. Yu. R. Kolobov, “Nanotechnologies for the Formation the Structure and Properties of Medical Implants Based on Titanium Alloys with Bioactive Coatings,” *Russ. Nanotekhnol.* **4** (11–12), 19–31 (2009) [*Nanotechnol. Russ.* **4** (11–12), 758–775 (2009)].
6. R. Z. Valiev, I. P. Semenova, V. V. Latysh, A. V. Shcherbakov, and E. B. Yakushina, “Nanostructured Titanium for Biomedical Applications: New Developments and Challenges for Commercialization,” *Russ. Nanotekhnol.* **3** (9–10), 80–89 (2008) [*Nanotechnol. Russ.* **3** (9–10), 593–601 (2008)].
7. R. Z. Valiev, “Preparation of Nanostructured Metals and Alloys with Unique Properties Using Severe Plastic Deformations,” *Russ. Nanotekhnol.* **1** (2), 208–216 (2006).
8. R. Z. Valiev and I. V. Aleksandrov, *Bulk Nanostructured Metallic Materials: Production, Structure, and Properties* (Akademkniga, Moscow, 2007) [in Russian].
9. Ya. E. Beigel’zimer, V. N. Varyukhin, C. G. Synkov, A. N. Saprionov, and V. G. Synkov, “New Schemes for Accumulating Severe Plastic Deformations with the Use of Hydroextrusion,” *Fiz. Tekh. Vys. Davlenii* (Donetsk, Ukr.) **9** (3), 109 (1999).
10. V. M. Segal, “Equal-Channel Angular Extrusion: From Macromechanics to Structure Formation,” *Mater. Sci. Eng., A* **271**, 322–333 (1999).
11. V. N. Varyukhin, V. Z. Spuskanyuk, N. I. Matrosoy, A. B. Dugadko, B. A. Shevchenko, E. A. Medvedskaya,

- L. F. Sennikova, A. V. Spuskanyuk, and E. A. Pavlovskaya, "Equal-Channel Multiangular Extrusion," *Fiz. Tekh. Vys. Davlenii (Donetsk, Ukr.)* **11** (1), 31–39 (2001).
12. K. Nakashima, Z. Horita, M. Nemoto, and T. G. Langdon, "Development of a Multi-Pass Facility for Equal-Channel Angular Pressing to High Total Strains," *Mater. Sci. Eng., A* **281**, 82–87 (2000).
 13. M. B. Ivanov, A. V. Penkin, Yu. R. Kolobov, E. V. Golosov, D. A. Nechaenko, and S. A. Bozhko, "Hot Cross Helical Rolling in Cone-Shaped Rolls as a Method of Severe Plastic Deformation," *Deform. Razrushenie Mater.*, No. 9, 13–18 (2010).
 14. Yu. R. Kolobov, M. B. Ivanov, E. V. Golosov, and A. V. Penkin, "A Method for Preparation of a Submicrocrystalline Structure in Unalloyed Titanium," RF Patent No. 2 389 568 (December 29, 2008).
 15. V. F. Terent'ev, *Fatigue Strength of Metals and Alloys* (Intermet Inzhiniring, Moscow, 2002) [in Russian].
 16. V. F. Terent'ev, "Endurance Limit of Metals and Alloys," *Metalloved. Term. Obrab. Met.*, No. 2, 47–56 (2008) [*Met. Sci. Heat Treat.* **50** (1–2), 88–96 (2008)].
 17. V. I. Betekhtin, Yu. R. Kolobov, E. V. Golosov, B. K. Kardashev, and M. V. Narykova, "Influence of Severe Plastic Deformation during Helical and Longitudinal Rolling on the Structure and Properties of the Titanium Alloy VT1–0," in *Proceedings of the XIX St. Petersburg Readings on the Problems of Strength, St. Petersburg, Russia, 2010* (St. Petersburg, 2010), Part 2, pp. 4–5.
 18. V. F. Terent'ev, "Fatigue Resistance of Titanium and Iron Alloys with Submicrocrystalline and Nanocrystalline Structures: A Review," *Metalloved. Term. Obrab. Met.*, No. 10, 21–28 (2007) [*Met. Sci. Heat Treat.* **49** (9–10), 476–483 (2007)].
 19. V. V. Stolyarov, "Mechanical Testing for Tension of Nanostructured Materials," *Zavod. Lab., Diagn. Mater.* **74** (1), 54–57 (2008).
 20. R. A. Andrievski and A. M. Glezer, "Strength of Nanostructures," *Usp. Fiz. Nauk* **179** (4), 337–358 (2009) [*Phys.—Usp.* **52** (4), 315–334 (2009)].
 21. Yu. R. Kolobov, A. G. Lipnitskii, M. B. Ivanov, and E. V. Golosov, "The Role of Diffusion-Controlled Processes in the Formation of the Structure and Properties of Metallic Nanomaterials," *Kompoz. Nanostrukt.*, No. 2, 5–32 (2009).
 22. Yu. Ivanisenko, L. Kurmanava, J. Weissmueller, K. Yang, J. Markmann, H. Rösner, T. Scherer, and H.-J. Fecht, "Deformation Mechanisms in Nanocrystalline Palladium at Large Strains," *Acta Mater.* **57**, 3391–3401 (2009).
 23. Yu. R. Kolobov, G. P. Grabovetskaya, M. B. Ivanov, A. P. Zhilyaev, and R. Z. Valiev, "Grain-Boundary Diffusion Characteristics of Nanostructured Nickel," *Scr. Mater.* **44** (6), 873–878 (2001).
 24. Yu. R. Kolobov, G. P. Grabovetskaya, K. V. Ivanov, and M. B. Ivanov, "Grain-Boundary Diffusion and Mechanisms of Creep of Nanostructured Metals," *Interface Sci.* **10** (1), 31–36 (2002).
 25. Yu. R. Kolobov, G. P. Grabovetskaya, K. V. Ivanov, M. B. Ivanov, and E. V. Naidenkin, "Diffusion and Plasticity of Submicrocrystalline Metals and Alloys," *Solid State Phenom.* **94**, 35–40 (2003).
 26. A. A. Il'in, B. A. Kolachev, and I. S. Pol'kin, *Titanium Alloys: Composition, Structure, and Properties: A Reference Book* (All-Russia Institute of Light Alloys, Moscow, 2009) [in Russian].
 27. T. Halton, E. D. Tabachnikova, and S. Surech, "Fatigue Behavior of Nanocrystalline Metals and Alloys," *Int. J. Fatigue* **27** (10–12), 1147–1158 (2005).