

# Decision Support System for Real-Time Diagnosis of Musculoskeletal System

Anastasia Grecheneva, Igor Konstantinov, Oleg Kuzichkin, and  
Nokolay Dorofeev

Belgorod National Research University, Belgorod,  
308015, 85 Pobedy st., Russia  
1155464@bsu.edu.ru  
<http://www.bsu.edu.ru/bsu>

**Abstract.** A construction principle of a technical system for diagnosis and rehabilitation of the musculoskeletal system based on accelerometer method, together with synchronization algorithms measuring patient parameters, is considered. The optimal accuracy estimations of the technical parameters of the accelerometric goniometer system are determined; they are the sample rates of the accelerometer signal converters, the required sensitivity of the sensor, *etc.* The advantages of the proposed approaches to the construction of rehabilitation and diagnostic systems of the musculoskeletal system are adaptability and reliability of the diagnoses.

**Keywords:** biomechanics, information system, goniometric control, accelerometer, mathematical model.

## 1 Introduction

Accurate diagnosis and objective assessment of the treatment efficiency of motor function disorders to date remains one of the urgent problems of modern traumatology and orthopedics. The large number of evaluation approaches and techniques reveal a lack of reliability of the proposed criteria for diagnosis and assessing recovery efficiency. For example, the diversity of human movement is characterized by a number of parameters: torque, speed, complexity of trajectories, changes in the level neuromuscular and brain activity. In existing systems, goniometry and diagnosis of musculoskeletal system mainly take into account only the kinematic parameters of the skeletal system, regardless of the bone structure and neurophysiological parameters of state of the patient [1]. Therefore, in diagnosis, the study of the central control mechanisms of purposeful physical activity is of great importance, as well as the parameters of the skeletal system at the structural level [2,3].

## 2 Statistical basis of the goniometric measurements

Formation of the goniometric criteria and selection of the optimal working parameters of the system rehabilitation is carried out on the basis of statistical

clinical studies of patients under normal conditions and in the presence of deviations. In medical diagnostics, the assessment of the angular movement indicators and their permissible deviation from the normal ones is done according to the joints motion estimation table “Regulations on military-medical examinations” (approved by the Russian Federation Government Decree No 565 dated July 4, 2013) [4].

**Table 1.** Assessment of range of motion in the joints of the limbs

Joint	Motion	Norm, °	Restriction of movement, °		
			slight	moderate	considerable
Shoulder to shoulder girdle	flexion	180	179-135	134-100	<100
	abduction	180	179-135	134-100	<100
Shoulder (simple)	extension	60	59-40	39-15	<15
	internal rotation	90	89-45	44-20	<20
	external rotation	90	89-45	44-20	<20
Elbow (complex)	flexion	30	31-70	71-90	>100
	abduction	180	179-150	149-120	<120
Combined elbow radial shoulder	wrist pronation	90	89-45	44-20	<20
	wrist supination	70	69-30	30-15	<15
Carpal (combined)	flexion	105	106-145	146-160	>160
	extension	115	116-150	149-165	>165
	radial abduction	160	161-175	176-185	>185
	ulnar abduction	140	141-155	154-180	>180
Hip (simple)	knee extension	90	91-120	121-150	>150
	knee flexion	60	61-90	91-150	>150
	extension	140	141-160	161-170	>170
	abduction	50	49-30	29-15	<15
	internal rotation	35	34-25	24-15	<15
external rotation	45	44-25	24-15	<15	
Knee (complex)	flexion	135	134-90	89-60	<60
	abduction	180	179-170	169-160	<160
Ankle (complex)	flexion	130	129-120	119-100	<100
	abduction	70	71-80	79-90	>90

On the basis of the data presented in Table 1, it can be said that indicator deviations of joint angles by 1° are violations. Consequently, goniometric system must meet the requirements of measurement accuracy, with the threshold sensitivity of the measurement of mutual deviations and measuring range of motion being at least 1°. In this case, the measurement error must be smaller than this threshold. It should be noted that at present mechanical goniometers are widely used in medical diagnostics. Their accuracy does not meet the present requirements stated by the system of this class. Low accuracy of the measured parameters might be resulted from the design features of the device, and a high

degree of subjectivity of diagnosis due to professional experience and the influence of the human factor [5].

### 3 Information and technical support of the automated systems of diagnostics of the musculoskeletal system

The emergence of the movement results from neuro-cerebral human activity aimed at the implementation of any function. Therefore, the main objective of the design of goniometric systems is to assess the effectiveness of motor actions with respect to the application efforts of their execution [6].

For a comprehensive solution of this problem, we are to study design aspects of an automated diagnostic system of human musculoskeletal apparatus. The design is based on the synthesis of adequate informative physiological methods such as goniometry (accelerometer), computed tomography, electroencephalography (EEG) and electromyography (ENMG). For this purpose, a medico-technical basis was formed. A block diagram of an automated system of complex real time diagnostics of the musculoskeletal system has been developed. The diagram consists of the circuit of accelerometric goniometer, an electroencephalograph and electromyography imaging is used as well (Fig. 1).

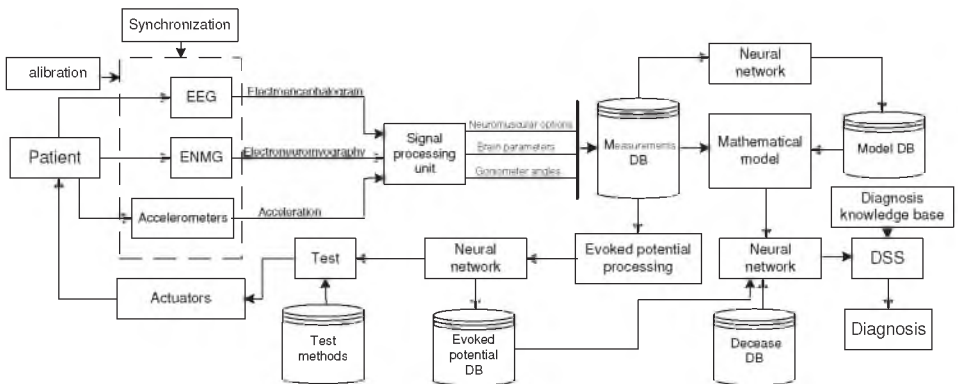
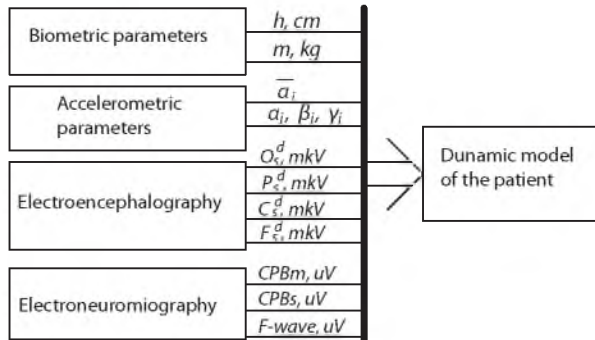

**Fig. 1.** A block diagram of hardware and software of the automated system of goniometric control

The above structure includes a measuring unit functioning in real time. It consists of a chain of inverters biokinematic driving parameters of the locomotor apparatus of man (accelerometric goniometer), recording units of psycho- and neurophysiological parameters (EEG and ENMG), and the registration equipment for bone and structural parameters (tomography).

The synchronous processing of the recorded parameters form time series, which are visualized with various degree of detail. The time series are the basis of a model of patient (Fig. 2). The model is processed by a neural network

and is stored in the model data base. The model that most closely matches the time series are instantiated. Pain thresholds and threshold of sensitivity of the patient for generating control signals to the actuators are determined by neural network algorithms. This is possible via a feedback method, whose implementation is carried out by the processing unit of evoked potentials of brain (patient’s reactions to test stimuli). Based on the processed data, operation mode of the actuators is generated and selected from a database of test techniques.

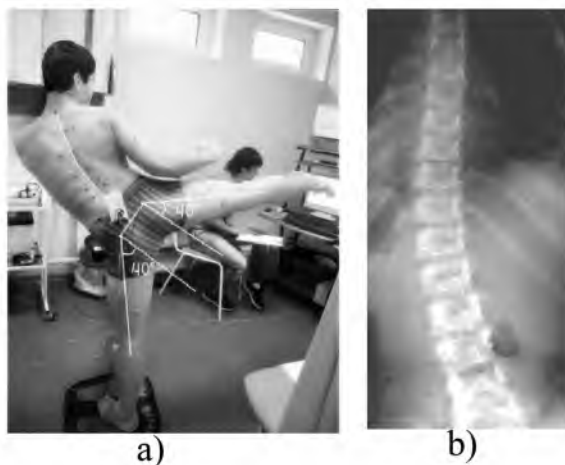

**Fig. 2.** The dynamic information model of patient

Thanks to neural network algorithms and decision support system (DSS) based on databases of the time series, diseases and evoked potentials, an approximate diagnosis of patient is determined.

It should be noted that the above adaptive goniometric control system includes both stationary and mobile measuring systems [6]. The number of monitored parameters is determined according to the severity of the patient’s pathology. In the case of low severity injuries, it is sufficient to use of a several portable accelerometric goniometers, guaranteeing the freedom of the patient’s movement. In the presence of more serious violations in the functioning of the musculoskeletal system is suspected, the accelerometric goniometers coupled with electroneuromyograph (Fig. 3a), EEG data and computing tomography (Fig. 3b) is recommended for use.

It is shown that the dynamic activity of brain neurons relating to the implementation of tool movements, typically starts 50-150 ms. prior to the occurrence of EMG activity and ended after a traffic stop. Thus, the joint reaches equilibrium during the dynamic development of the motor cortex neuronal activity phase long before the establishment of steady equilibrium level of neural activity. The maximum value of the mean frequency of neural activity in one bin of duration is 50 ms. In dynamic phase, reactions of neurons did not correlate with the magnitude of the equilibrium steady-articular angle (Fig. 5). At the same time, a positive correlation was revealed between the average frequency of neural



**Fig. 3.** Diagnostic biomechanics of the patient on the base of a physical exercise; a) the patient's posture; b) tomographic image

activity in the whole dynamic phase and magnitude response of articular angle [7, 8].

The presented results show that the maximum level of motor neuron activity depends primarily on the joint movement velocity and the duration of the movement. Thus, the obtained data contribute to definition of the criteria of permissible values, characterizing limits of the patient physiological parameters with respect to the normal ones; the limits are determined according to the degree of deviation and the conditions of pathology. Neurophysiological criteria are also formed based on statistical analysis of clinical studies of patients under normal conditions and in the presence of deviations.

#### 4 The DSS for setting of a diagnosis

Development of DSS based on the dynamics analysis of the recorded time series for goniometric, kinematic and neurophysiological parameters is a complex and multicriterial problem. The algorithms of the DSS are based on Bayes' rule. The rule accounts various heterogeneous types of input data expressing many kinds of deceases of the musculoskeletal system and a large number of symptoms. Bayes' rule in a generalized form is as follows [9]:

$$P(d | S_k \cap \dots \cap S_1) = \frac{P(S_1 \cap \dots \cap S_k | d) \cdot P(d)}{P(S_1 \cap \dots \cap S_k)}, \quad (1)$$

where  $P(d)$  is *a priori* probability of the diagnosis  $d$ , and  $S_1 \dots S_k$  are functional physiological parameters.

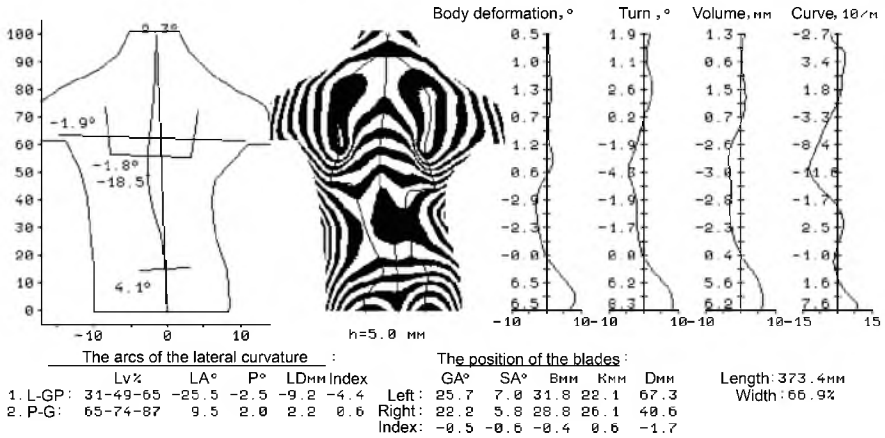

**Fig. 4.** Interpretation of results. Angle support limb (40 degrees) is not greater than (equal to) the angle of the working limb (40 degrees). The right lower limb: abduction angle in the hip joint is 40 degrees, the average EMG gluteus 1 is 563.6 mV. The left lower limb: abduction angle in the hip joint is 40 degrees, the average EMG gluteus is 893.5 mV.; muscle operation mode stabilizing. The ratio of the two coefficients of reciprocity for medium gluteus is 1.75.

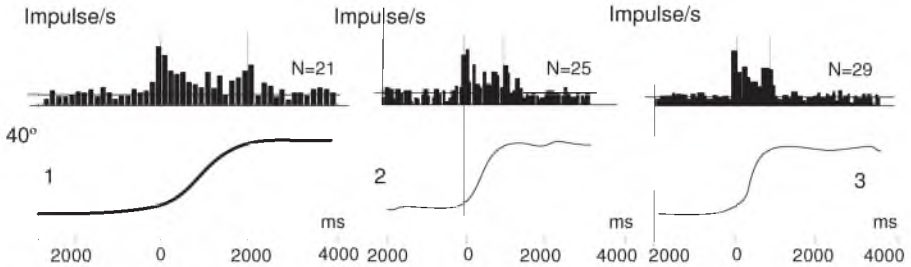

**Fig. 5.** The activity of neurons of the motor cortex and variations of the articular angle measured during the flexion movements at different joint velocity. Legend: 40° is the variation of the articular angle. The line parallel to the y-axis is the average frequency of pulses in the bin. The line parallel to the x-axis indicates the average frequency of the background activity of the neuron. Vertical lines indicate the boundaries of dynamic and stationary phases of motion. 1,2,3 are joint flexion speeds, N is number of iterations.

This formula requires  $(m \cdot n)^2 + m^2 + n^2$  calculations of probability estimates, where  $m$  is the number of possible diagnoses, and  $n$  is the number of different variations. In order to calculate the total probabilities  $P(S_1 \cap \dots \cap S_k)$ , we are to calculate  $P(S_1/S_2 \cap \dots \cap S_k) \cdot P(S_2/S_3 \cap \dots \cap S_k) \cdot \dots \cdot P(S_k)$ .

Therefore, the model  $P$  for automated diagnostic expert system will be based on

$$P(d | S) = \frac{P(S | d) \cdot P(d)}{(P(S | d) \cdot P(d) + P(S | \bar{d}) \cdot P(\bar{d}))}. \quad (2)$$

The probability of the hypothesis  $d$  in the presence of certain abnormalities in the recorded data  $S$  is calculated based on the prior probability of the hypothesis without confirming abnormalities and the likelihood of having abnormalities in conditions that hypothesis is correct (event  $d$ ) or incorrect (event  $\bar{d}$ ). Therefore, for the problem of diagnosis of diseases of the musculoskeletal system, it appears that

$$P(d | S) = \frac{P_{yes} \cdot P(d)}{(P_{yes} \cdot P(d) + P_{not} \cdot P(\bar{d}))}. \quad (3)$$

Let the pathology probability  $P(d)$  be equal to  $P$ . The program generates a condition (parameters in the presence of pathology) and calculates the probability  $P(d | S)$  depending on the it's implementation. The answer "Yes" ( $P_{yes}$ ) confirms the above calculations, the answer "No" ( $P_{no}$ ) does it too but with probability  $(1 - P_{yes})$ , and  $(1 - P_{no})$  instead  $P_{yes}$  and  $P_{no}$ . Thereafter, the *a priori* probability  $P(d)$  is replaced with  $P(d | S)$ . The program execution is cyclic, with the constant value  $P(d)$  refining at each iteration. The general scheme of the diagnosis selection algorithm is shown in Fig. 6.

The diagnosis selection algorithm structure consists of several branches:

Step 1. Enter the input data – a set of biometric, goniometric, neurophysiological and structural parameters; then the program retrieves information on the number of the diseases recorded having the corresponding symptoms from in the database ( $N$  is the number of relevant deviations disease,  $n$  is the number of the disease in question:  $0 \leq n \leq N$ ).

Step 2. Set counter of a disease incrementally from the initial state  $n = 0$  till  $n \leq N$ .

Step 3. Traverse all the *a priori* probabilities  $P(d)$ , relating to the input data set and to the selected disease, to prioritize detected deviations. Deviations with the minimal likelihood are excluded from the probability set ( $J$  is the selected number of deviations in the set,  $j$  the number of the current deviation  $0 \leq j \leq J$ ).

Step 4. Set the deviation counter incrementally from the initial state  $j = 0$  to  $j \leq J$ .

Step 5. Select the deviation with the greatest probability of presence.

Step 6. Evaluate the degree of reliability of the diagnosis according to the interval  $[-5, +5]$  (a scale). If the value belongs to the interval, then the program calculates the proportion of the degree of affiliation to a particular diagnosis parameters, using the corresponding weighting coefficients.

Step 7. Poll of the counter of registered deviations. If there is no new events of a decease then process the next unprocessed selected departure, go to step 4.

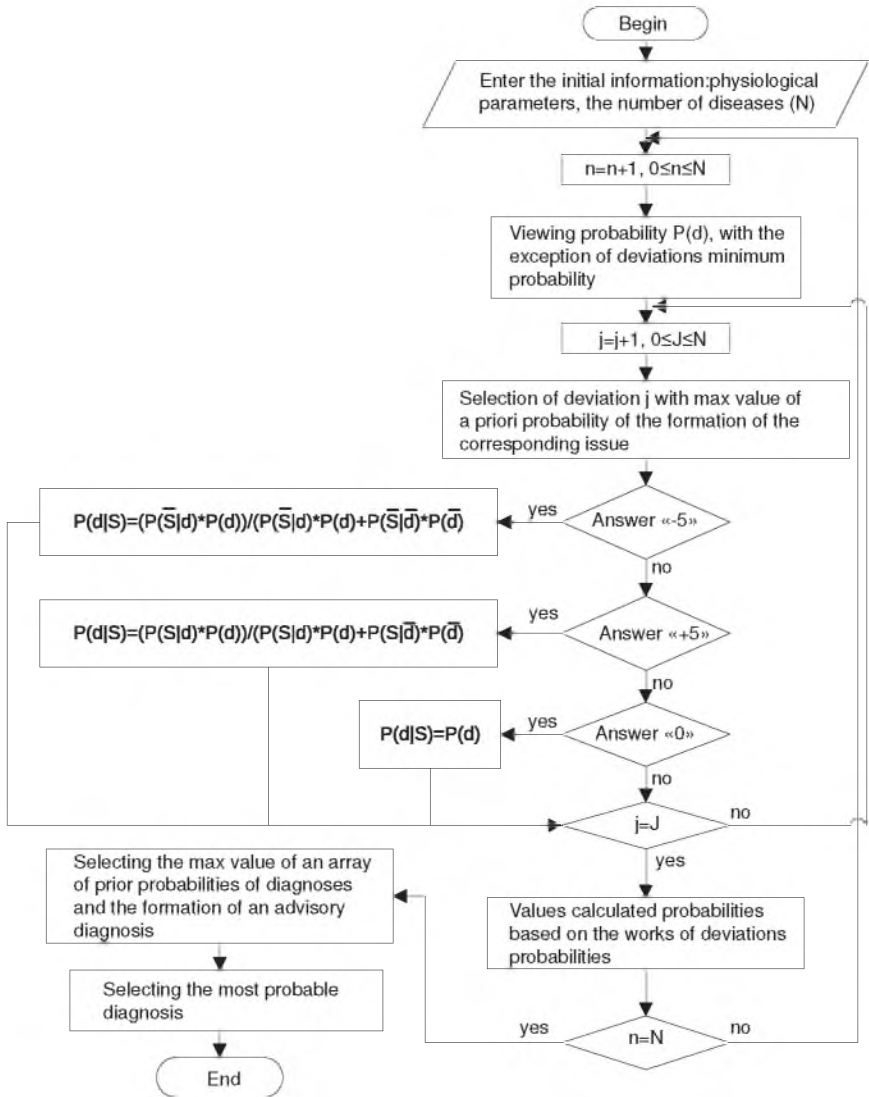

Fig. 6. The scheme of algorithm of diagnosis selection



Step 8. Figure out new probabilities in Bayes rules. Specify the minimal and maximal values of the probabilities for each disease based on the currently existing *a priori* probabilities and assumptions that the remaining evidence will speak in favor of the hypothesis or contradict it. This step calculates the total conditional probabilities for each deviations. The hypotheses whose the minimal values are above a certain thresholds are considered as possible outcomes (possible diseases) and are subject to further diagnosis.

Step 9. Check the counter of the registered diseases.

Step 10. Sort the outcome list according to the probabilities, display subset with the maximal probability values as a recommendation for the diagnosis mentioned symptoms to physician.

Step 11. Display the recommended diagnosis.

Medical information system, which implements this algorithm, produces a finite set of the recommendations for doctor, emphasizing the presence of deviations registered with the diagnostics system sensors. Limiting the selection decision by a finite set of possible diagnoses is to reduce the probability of setting wrong preliminary diagnosis, eliminate human factor and increase the objectivity of the diagnosis of diseases.

## 5 DSS based on fuzzy logic and artificial neural networks

In order to develop the control unit of diagnostics system of the musculoskeletal system, we propose a method of computer support of diagnosis setting based on fuzzy logic and artificial neural networks. The method is represented in the form of two structural units: decision-making unit and knowledge base.

The decision (a diagnosis) is produced in two stages [10]. At the first stage – the preliminary diagnosis–, the system determines in advance the possible pathology and generate diagnostic recommendations based on data from the medical records and X-ray images. Then, at the stage of the goniometric diagnosis, together with EMNG, the recommendations are confirmed or rejected on the basis of the analysis of the obtained information, with immediate neural network processing by the diagnosis system.

The advantage of fuzzy logic is the ability to describe the operation of the system by means of fuzzy production rules (FPR) [11, 12]. The initial values of the parameters (used in FPR) for the normal cases or the pathological ones are determined at the beginning on the base of experts' opinions. The values are adjusted with neural network engines.

A distinctive feature of this set of rules is the allocation of a separate group of so-called factors of pain diagnosed by EEG. Pain is one of the most important factors in the diagnosis of diseases of the musculoskeletal system. On the basis of these features we justify the choice of the rules of fuzzy productions of the form:

```
IF <Condition1 = true> AND ... AND <ConditionN = true>
THEN <Consequent1 = true> AND ... AND <ConsequentN = true>
```

Necessary linguistic input variables ( $IN_{LV}$ ) are selected according to a statistical base of the analysis of medical records and printed materials [13].

Membership functions (MF)  $\mu$  of a strict magnitude to a fuzzy term set (corresponding to one of the values of the input linguistic variables) were determined by means of the following expert evaluation techniques. Let expert  $E_1$  believe that the specific value of  $x^*$  belongs to the fuzzy term set at  $a_1 \leq x^* \leq b_1$ ; expert  $E_2$  at  $a_2 \leq x^* \leq b_2$ ; ...;  $E_g$  expert at  $a_g \leq x^* \leq b_g$ . Then the term of MF  $\mu$  is obtained in the form shown in Figure 7.

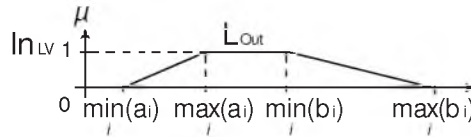

**Fig. 7.** The membership function of a term.  $IN_{LV}$  is input linguistic variable,  $LOut$  is a linguistic output

In the figure, the horizontal axis shows the value of strict variable under fuzzification, where  $i = \overline{1, g}$  is an expert number. The vertical axis displays  $\mu$  fraction of all the experts who believe that its value of a  $x$  belongs to this linguistic value of the linguistic variable. This initially plots the MF's, which is obtained at  $x \in (min(a_i), max(a_i)) \cup (min(b_i), max(b_i))$ ; the plot is curvilinear and will get a linear form if the least squares method is used.

The next stage is the aggregation construction applied to the RFP's whose terms contain more than one sub-conditions. The conditional part of the rules is as follows:

IF  $\langle IN_{LV1}=VALUE11 \rangle$  OR ... OR  $\langle IN_{LV1}=VALUE1m \rangle$   
 AND  $\langle IN_{LVn}=VALUEn1 \rangle$  OR ... OR  $\langle IN_{LVn}=VALUEnm \rangle$

Each of the  $n$  terms  $\langle IN_{LVi}=VALUEi1 \rangle$  OR ... OR  $\langle IN_{LVi}=VALUEij \rangle$  consists of  $m$  subconditions  $\langle IN_{LVi}=VALUEij \rangle$ , where  $VALUEij$  is the  $j$ -th value of the  $i$ -th  $LV$  in subconditions. Its number is determined by the number of input values  $LV : i\hat{j}$ . Let the truth degree of subconditions with the number  $i\hat{j}$  be, respectively,  $\mu_{ij}$ . The following RFP matrix  $M$  is formed for all the subconditions:

$$M = \begin{pmatrix} \mu_{11} & \mu_{12} & \cdots & \mu_{1m} \\ \mu_{21} & \mu_{22} & \cdots & \mu_{2m} \\ \vdots & \vdots & \ddots & \vdots \\ \mu_{n1} & \mu_{n2} & \cdots & \mu_{nm} \end{pmatrix}. \quad (4)$$

Using this matrix at the 3-6-th stages, we get the formula for calculating the confidence coefficient  $\chi$  – the correctness precision of the system solution, – which is calculated for each of the possible diseases identified by DSS.

$$\chi_u = \int_{max}^{min} y_u \cdot \max_v \left( \tilde{\mu}_{uv} \cdot \frac{\sum_{k=1}^{q_{uv}} F_k \cdot \min_i (\max_j (\mu_{ij}(x_i)))}{\sum_{k=1}^{q_{uv}} F_k} \right) dy_u / \int_{max}^{min} \max_v \left( \tilde{\mu}_{uv} \cdot \frac{\sum_{k=1}^{q_{uv}} F_k \cdot \min_i (\max_j (\mu_{ij}(x_i)))}{\sum_{k=1}^{q_{uv}} F_k} \right) dy_u, \quad (5)$$

where  $min$  and  $max$  are the left and right limits of the carrier interval of fuzzy set  $LOut\omega_u$  under consideration;  $F_k$  are the weighting coefficients of the rules,  $k = \overline{1, q_{uv}}$ ;  $q_{uv}$  is the number of RFP, which is determined in the consequent of the  $u$ -th term of MF  $LOutv$ ;  $\tilde{\mu}_{uv}(y_u)$  is the antecedent MF  $v$ -th term of  $u$ -th MF  $LOut$ .

It should be noted that the weights of the rules vary depending on the occurrence of new facts and results of fuzzy inferences at the previous stages. To resolve this uncertainty in form of an adjustment of RFP weights, an inference system is represented as a hybrid, *i.e.*, fuzzy neural network (Fig. 8). Its structure is identical to the multilayer network, but its layers correspond to the stages of fuzzy inference, which has continuously carry out the following procedures:

- Input layer performs fuzzification function based on the specified input membership functions;
- Output layer implements the defuzzification function;
- Hidden layers reflect the totality of the RFP and the output stages: aggregation, activation and accumulation.

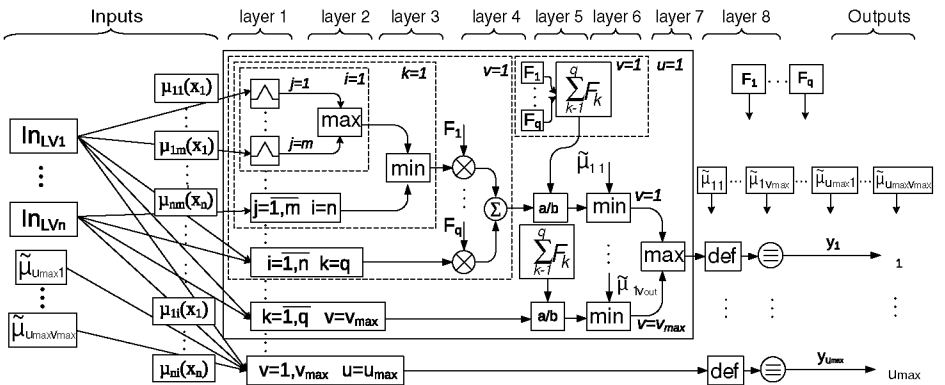

Fig. 8. The structure of hybrid neural network

Neurons *min*, *max* and *sum* indicated in Fig. 8 act as appropriate mathematical functions. Neurons, marked with “×” is transmitted to the output product of the input signals. Symbol “≡” marks neurons establishing a correspondence between *LV* and an intermediate *LOut*, and symbols “∧” are neurons realizing operation fuzzification for each term of INLV. Node “*a/b*” denotes division of the input value by the sum of the weights of active rules. Neuron “*def*” implements the function of defuzzification, with applying the method of gravity center.

The fuzzy rule selection engine is represented as INLV inputs having “0” (a rule is selected) and “1” (a rule is not selected) logic levels weights multiplied by the corresponding membership functions  $\mu_{ij}(x_i)$ . Here index  $i \in \overline{1, n}$  is the number of  $IN_{LV}$  and index  $j \in \overline{1, m}$  is the number of its term.

A neural network is trained by the algorithm of error back-propagation modified for use in the fuzzy neural networks. The layers of neurons with specified parameters are represented by one layer with a complex activation function, fuzzy artificial neural network (ANN) is identical a three-layer ANN with one hidden layer. Thus, network training is reduced to a three-layer perceptron learning. It is worth noting that the fuzzy neural network is used only in the case of changes of the DSS structure (change aggregate RFP, input or output LV), and in the case of the appearance of new evidence proving or disproving the previously known data in the literature or medical practice.

## 6 The results of research

This section is devoted to the results of the benchmark tests of the calculated model; the results are obtained with an installed bodily machinery of the human skeleton. During the investigation, we used the method of mechanical goniometry in collaboration with an orthopedic doctor. The method of accelerometer goniometry usage is proposed in [5].

**Table 2.** Average values of measurement errors for accelerometric and mechanical goniometers

Motion pattern	Error of an accelerometric goniometer	Error of a mechanical goniometer
Bending	±0,02	±1,00
Abduction	±0,02	±1,00
Extension	±0,02	±1,00
Internal rotation	±0,02	±1,00
External rotation	±0,02	±1,00
Tremor imitation	±0,02	±3,50

The results in Table 1 confirmed that the application of the accelerometric goniometer improves the diagnosis accuracy in average 1° 44' compared to mechanical goniometer.

In addition, the diagnosis was carried on 20 patients who underwent rehabilitation after complicated shoulder injury and wrist. It should be noted that in all cases the diagnosis was a medical opinion on the normal rates. However, based on the neural network processing of the recorded data of the goniometric control, the electroneuromyographic and the tomographic control, a dial of a estimation of a motion in the joints from the Table 1, it was found that in 14 cases the medical diagnosis coincided with the diagnosis of DSS, in 4 cases were diagnosed of a functional deviation of the work wrist in a small extent, and in 2 cases were more prominent deviation of the combining elbow-shoulder joint in small extent.

## 7 Conclusion

Data processing algorithms and approaches to designing a system of diagnostics of the musculoskeletal system are presented in the article. The obtained results allow one to

- define the evaluation criteria of the “current state” of the musculoskeletal system;
- determine the severity of biomechanical disorders with a high degree of confidence;
- predict the biomechanical disorders of the musculoskeletal system;
- have the possibility of a science-based rehabilitation prognosis;
- create and optimize individual training programs that promote the advancement of technical training of athletes and prevent the diseases.

The results show that the diagnosis of the functional state of the musculoskeletal system based on the proposed system is an informative method of detecting violations. This technique is recommended to be used as a supplement to conventional methods of examination of the musculoskeletal system condition, as well as a stand alone technique.

**Acknowledgments.** This work was supported by RFBR grant 16-38-00704\_mol\_a.

## References

1. Vitenzon, A.S., Petrushanskaya, K.A.: The concept of the use of artificial correction movements in orthopedics, traumatology and prosthetics. In: Journal of Traumatology and Orthopedics. Priorov. - 2003. - No 4. pp. 54-58.
2. Hecht, B.M., Kasatkina, L.F., Samoylov, M.I. *et al.*: Electromyography in the diagnosis of neuromuscular diseases. - Taganrog: TSURE, 1997. - 370 p.
3. Drew, T., Kalaska, J., Krouchev, N.: Muscle synergies during locomotion in the cat: a model for motor cortex control // J Physiol. - 2008.- Vol. 586, No 5. - P. 1239-1245.
4. Resolution of the Russian Government dated on July 4, 2013 N 565 "On approval of the military-medical examination" <http://docs.cntd.ru/document/499031795>.

5. Grecheneva, A.V., Kuzichkin, O.R., Dorofeev, N.V., Konstantinov, I.S.: The use of the accelerometer in the goniometric measurement system. In: Information systems and technologies, ISSN 2072-8964, No 4 (90) 2015 July-August, pp. 5-10.
6. Grecheneva, A.V., Dorofeev, N.V., Kuzichkin, O.R.: The use of the accelerometer in the goniometric measurement systems. In: Mechanical engineering and life safety, ISSN 2222-5285, No 1, 2015. pp 55-58.
7. Sarnadskiy, V.N., Fomichev, H.G., Monitoring of spinal deformity by computer optical topography. - Benefit For Physicians Health Ministry. -Novosibirsk, NIITO 2001.
8. Zokirhodzhaev, M.A.: Diagnostic criteria and methods of rehabilitation therapy flat feet in children. In: The doctor-graduate student, No 5.2 (54), 2012. - P. 234-239.
9. Kobrinsky, B.A.: The logic of the argument in the decision-making in medicine. In: STI ser.2. - 2001. - No 9. - P. 1-8.
10. Podolny, M.A., Taperova, L.N.: Designing medical diagnostic system based on the model of fuzzy inference. In: Eighth Nat. Conf. by Art. Intelligence with int. uch. : mat. Conf. V.2. M. : FIZMATLIT, 2002. - P. 641-646.
11. Babkin, E.A., Kozyrev, O.R., Kurkina, I.V.:The principles and algorithms of artificial intelligence, Nizhny Novgorod: Nizhegorod. state. tehn. University Press, 2006. 132 p.
12. Chernov, A.V., Shtanko, S.I., Rogozin, M.A., Podvigin, S.N.: The use of mathematical analysis for the diagnosis of borderline mental disorders in medical students. In: Doctor-graduate student, No 1 (50), 2012. P. 43-49.
13. Choporov, O.N., Razimkin, K.A.: Optimization model of choice of the initial plan of control actions for modeling information systems. In: Control Systems and Information Technology, 2011. Vol. 46, N 4.1. P. 185-187.